

VAPOR BOX



SPECIFICATIONS and OPTIONS

Simple and easy to operate. It is not necessary to be an expert in garment finishing. The compact overall dimensions allow the installation and operation even in small premises.

The high speed of the finishing cycle and zero idle working times, produce high output performance with a significant saving of energy.

The finishing cycle is carried out without the slightest waste of steam, providing an improved working environment.

Vapor Box is supplied as standard with one trouser finishing device and one form finisher for jackets, coats, dresses etc. Thanks to a very easy fitting system, the cabinet can be transformed and equipped with two trouser finishing devices or two form finishers.

This will depend on the operator's needs, and the modifications can be carried out without any technical assistance.

The working cycle is automatic and can be adjusted by three timers.

The machine is available in the self contained version (VAPOR BOX/A), with built-in electric and automatic steam boiler or for central steam supply (VAPOR BOX/V).

Vapor Box is supplied complete with all the necessary accessories for the finishing of the trousers and of the jackets and coats, as shown.

Vapor Box is now available with a new easy to use computer control system.

Capable of running up to nine fully automatic programs.

Standard accessories

1. Trousers waist band stretcher
2. Curved clamps for jackets and coats
3. Vertical clamps
4. Wooden sleeve stretchers
5. Dummy
6. Multiple connection
7. Straight trouser clamps
8. Silicon sleeve stretchers

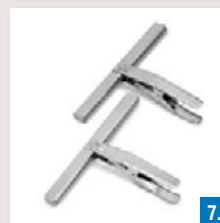
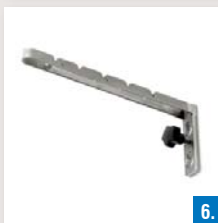
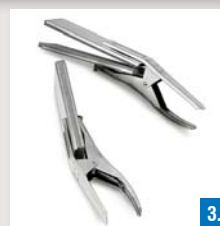
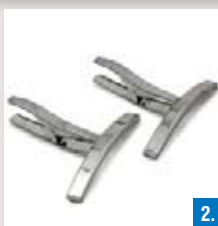
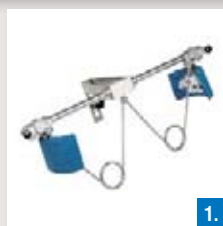

Available options on request

1. Leg stretching carriage with support
2. Automatic starting of the working cycle after closing the cabinet door
3. Pneumatic operated air discharge valve
4. Pneumatic waist band stretcher

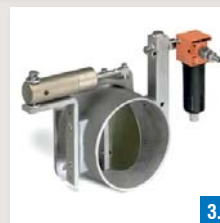
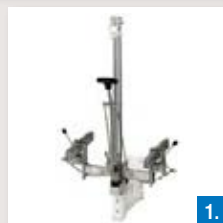

Technical Specifications

VAPOR BOX "A"

VAPOR BOX "V"

Dimensions:

Voltage	230V/400V/3/50-60 Hz	230V/400V/3/50-60 Hz
Water feeding	Ø 3/8"	--
Steam inlet	--	1/2"
Air inlet	Ø 1/4"	Ø 1/4"
Steam working pressure	4 ÷ 5 bar	--
Air working pressure*	4 ÷ 5 bar	4 ÷ 5 bar
Steam consumption	16 ÷ 20 Kg/h	16 ÷ 20 Kg/h
Air consumption*	6 l/h	6 l/h
Boiler heater	7-10-12-15-18 kW	--
Fan motor	1-1,5 HP	1-1,5 HP
Pump motor	0,75 HP	--
Air outlet	Ø 140 mm	Ø 140 mm
Boiler exhaust	Ø 1/2"	--
Overall dimensions	1080x1375x1850 mm	1080x1375x1850 mm
Net weight	241 Kg	180 Kg
Gross weight (crate)	309 Kg	248 Kg
Packing dimensions	1080x1190x2020 mm	1080x1190x2020 mm
Volume	2,61 m ³	2,61 m ³

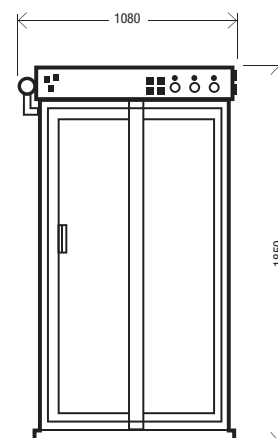
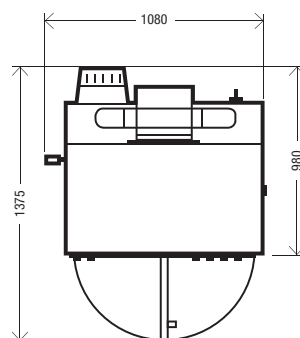

* If requested

The firm reserves the right to make any necessary modification without notice.